



I. Functions and characteristics

All of our current transformers (CTs) have been designed with care to provide accuracy and consistency, in conjunction with our Omnimeter line of kWh meters, for a wide variety of users and use cases.

II. Technical Specifications

- Model: ESCT-055-600UL
- Type: Split Core
- Rated Input: 0.25-600 Amps
- Inside Diameter: 55mm
- Outside Diameter: 108mm
- Output: 26.6mA
- Accuracy: $\pm 0.1\%$ accurate.
- When used in conjunction with our Omnimeters, the installation will have an accuracy of $\pm 0.5\%$.
- Leads: 6 feet, 22AWG
- Internal windings: 23,076
- Frequency: 50–400Hz
- Operating Temperature: -40°F – 158°F
- Storage Temperature: -49°F – 185°F
- The arrow points towards the load.
- ANSI C57.13 and IEC60044-1 Standards
- Approved for UL and cUL installations when used in conjunction with our UL and cUL Listed Omnimeters.

III. How to Choose CTs

When choosing current transformers, you should consider four factors:

How many CTs do I need for my electrical system?

Use 1 CT for 120 volt (or foreign 2-wire systems).

Use 2 CTs for a 120/240V three-wire system (two hots and a neutral, with or without ground).

Use 2 CTs for 3-phase 3-wire systems (3 hots and no neutral).

Use 3 CTs for 3-phase 4-wire systems (3 hots and a neutral).

What is the wire diameter that needs to pass through the CT?

What is the maximum amperage of the system being metered? Do you want CTs that open (split core), or are closed (solid core)?

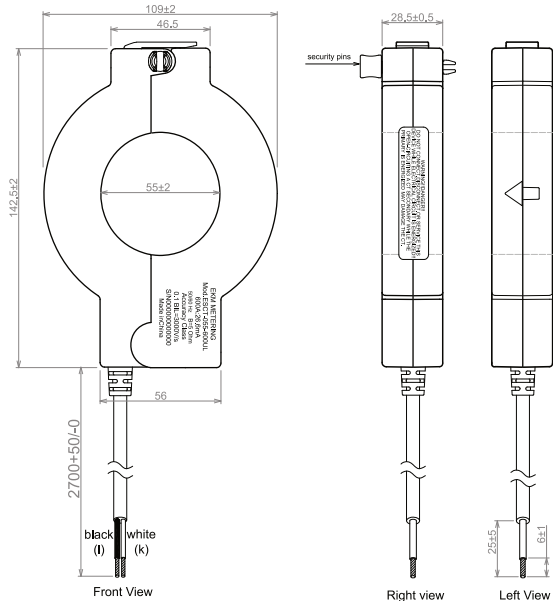

IV. Installation

- 1.) Install in a protected environment or enclosure. decrease accuracy.
- 2.) We recommend that you do not lengthen the CT leads as this may
- 3.) We recommend that you install this current transformer while the circuit is powered down.
- 4.) Open the CT by pressing the small pin on the rim of the CT and gently pulling the CT apart.
- 5.) Be sure that the metal contact pads inside the CT are clean.
- 6.) Close the CT around the wire to be measured and press firmly until you feel and hear it click to indicate full closure. (taping or adding a zip tie around the CT rim can also help ensure that the both sides of the CT remain in contact.)
- 7.) Connect the two wire leads to the appropriate terminals on your meter. Do not open circuit the CT secondary while the primary is energized. If the primary is energized while the CT is not connected to a meter, short the wire leads (join the two ends) to avoid damaging the CT.

